

Customer:		
Project:		
Architect/Engineer:		
Contractor:		
Drawing No.:	Date:	Sheet of

Shop Drawing

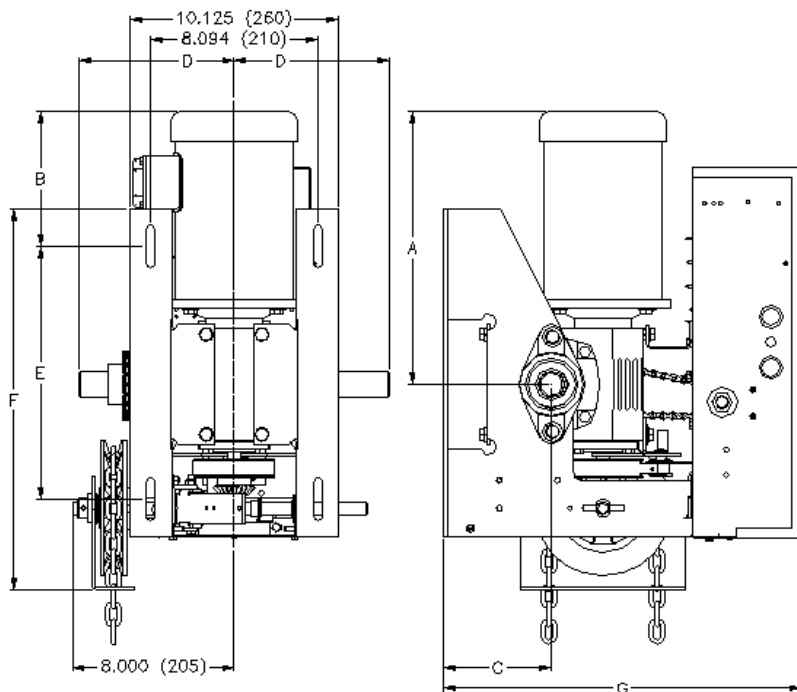

Dimensions	UP TO 1.5 HP	2 TO 3 HP
A	17.125 (435)	20.750 (530)
B	10.375 (265)	14.000 (360)
C	5.250 (135)	5.875 (150)
D	7.500 (195)	8.000 (205)
E	12.375 (315)	12.625 (325)
F	16.000 (410)	15.875 (405)
G	17.500 (445)	18.875 (480)

Motor Amperage Rating					
HP	Voltage - Phase				
	115 V - 1 Ph	230 V - 1 Ph	208 / 230 V - 3 Ph	460 V - 3 Ph	575 V - 3 Ph
1/2	9.0	4.5	2.2	1.1	-
3/4	11.2	5.6	3.2	1.5	1.2
1	13.6	6.8	3.7	1.7	1.4
1 1/2	19.6*	9.8	5.3	2.5	2.0
2	-	-	6.5*	3.1*	2.5*
3	-	-	8.5*	4.1*	3.3*
5	-	-	16.7*	7.6*	6.1*

* ECB not available

• Specifications For Ordering

Quantity:		Model Number:			
HP:	Amperage:	Volts:	Phase:	Hertz:	
Motor Circuit Type: (Circle One) Contactor or ECB					
Door Type:		Width:	Height:	Lift:	
Hand Chain: (Circle One) Left or Right		Drive Sprocket: (Circle One) Left or Right			
Friction Clutch: (Circle One) Left or Right		Drive Sprocket & Chain: (Circle One) #50 or #60			
Supply	3-Push Button Station(s) in NEMA			Enclosure Per Operator	

Supply Auxiliary and Optional Equipment as specified below: One per operator unless otherwise noted.

• Notes:

1. Refer to model MGH Specification Sheet for General Information
2. Refer to Drawing _____ for Wiring Diagram