

Specification Sheet

MGSLD

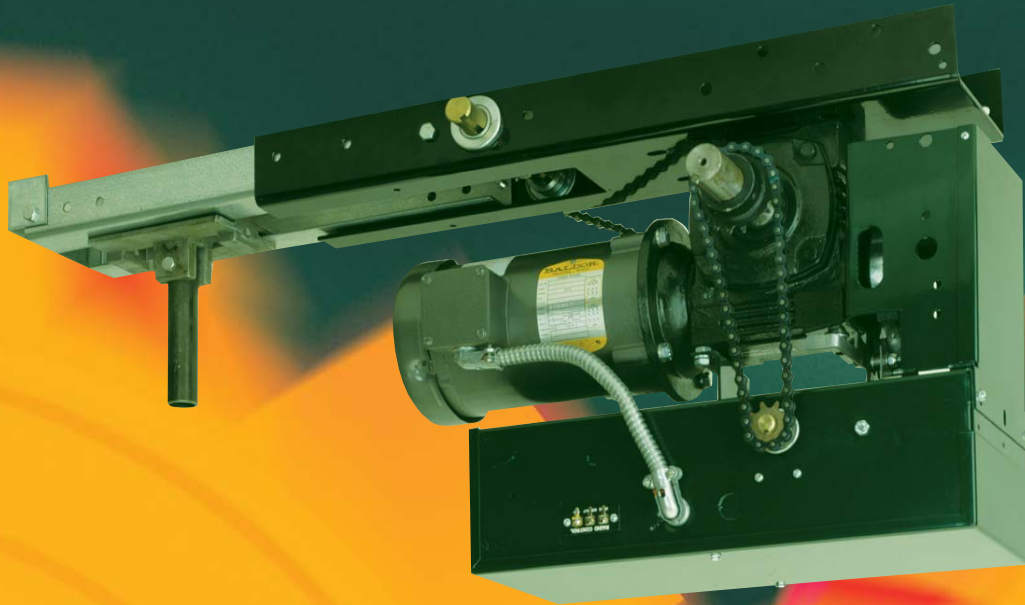

MGSLD, a very heavy duty WORM GEAR operator with solenoid brake for industrial sliding doors.

Manaras®

• Standard Features

Motor: 60Hz high starting torque, continuous-duty industrial type, 1 phase capacitor start or 3 phase motor, open drip proof with totally enclosed ends, protected against overload. Also available with 50Hz 220V 1 phase and 380V 3 phase motor, consult inside sales.

Reduction: worm gear in oil bath reducer, additional step by #41 chain and sprocket giving a door speed of 10"/second. Output shaft is 1" supported by ball bearings.

Drive and Trolley Assembly: #41 full roller chain drive. Dual, 12 gauge, pre-drilled galvanized tracks. Track spacers 3/4" steel shaft. Trolley made of cast aluminum alloy with possibility of chain tension adjustment.

Clutch: friction type, integrated in reducer, adjustable from outside.

Brake: electrically activated drum type solenoid brake.

Manual Operation: quick release disconnect device for manual sliding operation.

Electrical Enclosure: all electrical components are in a NEMA 1 enclosure.

Limit Switches: rotary-type with oil-impregnated steel cams, commercial grade switches. Systems are enclosed in electrical control box and limit shaft is supported by ball bearings. Remains in time when there is a manual operation or after the motor as been removed.

Corrosion Protection: frame and control enclosure protected by a baked on, long lasting enamel finish. All shafts protected by yellow chromate coating.

• Motor Control

Contacting Units: 24VAC control circuit, 40VA class II transformer, fuse protected on output, heavy-duty across-the-line linear reversing contactor with mechanical interlock. C2 wiring is standard. B2 can be set very easily by moving one wire. Available options: delay on reverse, timer to close, double limits, etc...

or

ECB Units: 24VDC relaying and 5VDC logic circuit with a 40VA class II transformer, non-volatile memory. Features included: 1.5s delay on reverse, programmable maximum run timer, mid-stop, timer to close, programmable advance close system, test buttons, reverse wiring detection and door lock sensor. Operating mode selectable on site: C2, B2, D1, E2, T or TS.

• Main Options

Control Accessories: terminal strip allows for the connection of 3-button stations (one supplied with the operator), sensing edges, photo cells, one push button radio control (external strip), ceiling pull and key switches, loop detectors, external interlocks. Fuse protected 24VAC output is available for accessory power supply.

Environmental Modifications: NEMA 4/12, NEMA 4X and NEMA 7/9 enclosures.

Mechanical Accessories: hardware available for single operated bi-parting doors, etc..., consult inside sales.

2 Year Warranty



• Operator Range

Current Consumption (Amp.)

Horse Power	115V 1 Ph	230V 1 Ph	208/ 230V 3 Ph	460V 3 Ph	575V 3 Ph	General Guideline
1/2	9.0	4.5	2.2	1.0	-	
3/4	11.2	5.6	3.2	1.5	1.2	
1	13.6	6.8	3.7	1.7	1.4	
1-1/2	19.6*	9.8	5.3	2.5	2.0	

* ECB not available

• Dimensions

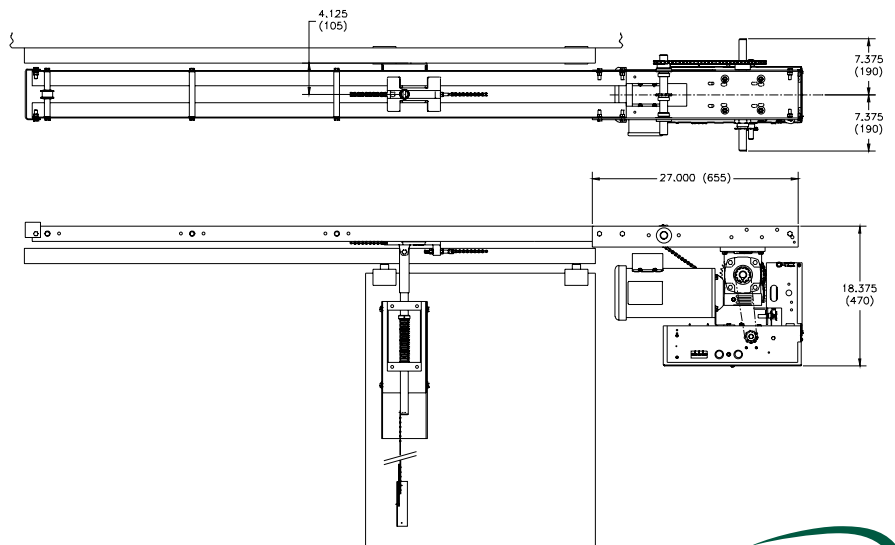

Approx. shipping weight: 137 lbs – 62 kg + op. tracks

Manaras-Opera reserves the right to make specification or design changes without prior notice.
Reg. T.M. of 9141-0720 Québec Inc.

