

An apartment garage operator for industrial standard lift sectional doors with high cycling daily frequency requirements. It incorporates a solenoid brake.

Standard Features

• Construction

- APT1** - dual 4L/A V-belt
- APT2** - dual 4L/A V-belt + wired for warning lights
- APT3** - single 4L/A V-belt
- APT4** - dual 4L/A V-belt + instant reverse motor

Continuous duty industrial motor (60Hz)
 4L/A V-belt, chain and sprocket reduction
 Solenoid brake
 Heavy duty 1" output shaft
 Ball bearings at all critical points
 #41 roller chain drive *
 Door speed: 9"/second (reduced for quieter operation and longer lifetime) *
 Dual, heavy gauge, pre-drilled galvanized tracks
 Green baked-on long lasting enamel finish
 Rotary type limit switches
 Motor removable without affecting limits
 Approximate shipping weight:
 73 lbs – 33 kg + op. tracks

2 Year Warranty

Typical Installation

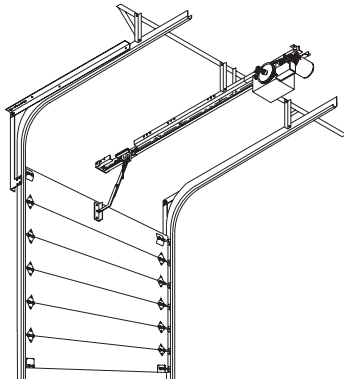

• Safety Features

- Quick release disconnect arm for manual operation
- Adjustable friction clutch
- Full overload protection



• Control Circuit

Contacting Units: 24VAC control circuit, 40VA class II transformer, fuse protected on output, heavy-duty across-the-line linear reversing contactor with mechanical interlock. C2 wiring is standard. B2 can be set very easily by moving one wire. Timer to close is standard. Extra relay added to warranty safety reverse on the complete door travel *.

* unique to APT and APE models

Dimensions

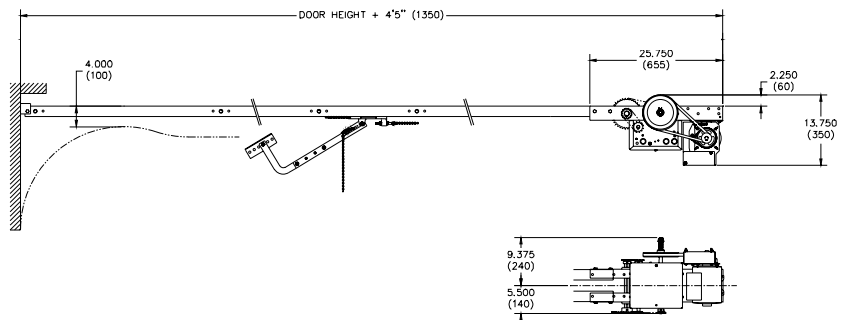

• Ordering:

To place your order please select first the operator code according to the horsepower, voltage and phase and also the track hardware code according to the door height. Please advise if any options are required.

• Operator Range

		Code	Volt	Ph	Amp.
APT1	1/2 HP	MTBH-6112-APT1	115	1	8.0
		MTBH-6212-APT1	230	1	4.0
		MTBH-6232-APT1	208	3	2.1
		MTBH-6432-APT1	460	3	1.0
		MTBH-6532-APT1	575	3	0.8
	3/4 HP	MTBH-6113-APT1	115	1	11.2
		MTBH-6213-APT1	230	1	5.6
		MTBH-6233-APT1	208	3	3.2
		MTBH-6433-APT1	460	3	1.5
		MTBH-6533-APT1	575	3	1.2
	1 HP	MTBH-6114-APT1	115	1	13.6
		MTBH-6214-APT1	230	1	6.8
		MTBH-6234-APT1	208	3	4.4
		MTBH-6434-APT1	460	3	2.1
		MTBH-6534-APT1	575	3	1.6

		Code	Volt	Ph	Amp.
APT3	1/2 HP	MTBH-6112-APT3	115	1	8.0
		MTBH-6212-APT3	230	1	4.0
		MTBH-6232-APT3	208	3	2.1
		MTBH-6432-APT3	460	3	1.0
		MTBH-6532-APT3	575	3	0.8
	3/4 HP	MTBH-6113-APT3	115	1	11.2
		MTBH-6213-APT3	230	1	5.6
		MTBH-6233-APT3	208	3	3.2
		MTBH-6433-APT3	460	3	1.5
		MTBH-6533-APT3	575	3	1.2
	1 HP	MTBH-6114-APT3	115	1	13.6
		MTBH-6214-APT3	230	1	6.8
		MTBH-6234-APT3	208	3	4.4
		MTBH-6434-APT3	460	3	2.1
		MTBH-6534-APT3	575	3	1.6

		Code	Volt	Ph	Amp.
APT2	1/2 HP	MTBH-6112-APT2	115	1	8.0
	3/4 HP	MTBH-6113-APT2	115	1	11.2
	1 HP	MTBH-6114-APT2	115	1	13.6

		Code	Volt	Ph	Amp.
APT4	1/2 HP	MTBH-6112-APT4	115	1	8.0
		MTBH-6212-APT4	230	1	4.0

APT4 only available on 115/230V 1Ph 1/2HP operators.

APT2 standard in 115V 1Ph. For other voltages, please consult inside sales.

• Track Hardware

For more details about the track hardware, please consult inside sales.

For 50Hz operators, please consult inside sales.

	Code	Door height
#41	T107	Up to 7'
	T108	Up to 8'
	T110	Up to 10'
	T112	Up to 12'
	T114	Up to 14'
	T116	Up to 16'
	T118	Up to 18'
	T120	Up to 20'

Options

• Mechanical Modifications

Modification No	Options
MOD055	Double 4L V belt
MOD069	Pillow block bearings on input shaft
MOD072	Pillow block bearings on output shaft
MOD073	Very heavy duty front idler

To help extend the life of the drive system, pillow block bearings and a very heavy duty front idler (with ball bearings) can be installed.

• Electrical Modifications

Modification No	Options
MOD003	Delay on reverse 1.5s
MOD008	Double limit switch (per pole)