



An apartment garage door operator for industrial standard lift sectional doors with high cycling daily frequency requirements.

Standard Features

• Construction

- Continuous duty industrial motor (60Hz)
- 4L/A V-belt, chain and sprocket reduction
- Heavy duty 1" output shaft
- Pillow block bearings on input shaft
- Ball bearings at all critical points
- #41 roller chain drive *
- Door speed: 9"/second (reduced for quieter operation and longer lifetime) *
- Dual, heavy gauge, pre-drilled galvanized tracks
- Green baked-on long lasting enamel finish
- Rotary type limit switches
- Motor removable without affecting limits
- Approximate shipping weight:
71 lbs – 32 kg + op. tracks

2 Year Warranty

• Safety Features

- Quick release disconnect arm for manual operation
- Adjustable friction clutch
- Full overload protection



• Control Circuit

Electronic Control Board with 5Vdc logic: Options included: B2, E2 wiring, timer to close, mid-stop, maximum run timer, programmable advance close system, test buttons, reverse wiring detection, delay on reverse and door lock sensor.

* unique to APE and APT models

Dimensions

Typical Installation

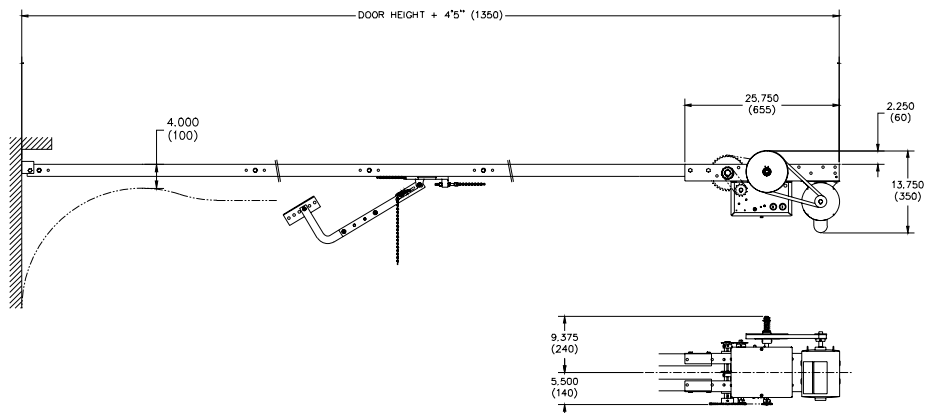
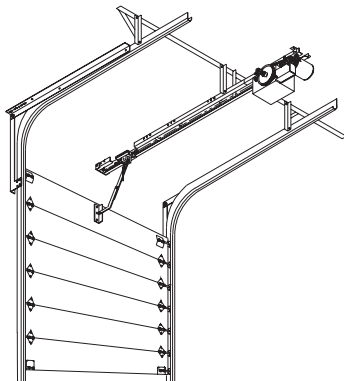

• Ordering:

To place your order please select first the operator code according to the horsepower, voltage and phase and also the track hardware code according to the door height. Please advise if any options are required.

• Operator Range

	Code	Volt	Ph	Amp.	
APE0	1/2 HP	MTH-6112-APE0	115	1	8.0
		MTH-6212-APE0	230	1	4.0
		MTH-6232-APE0	208	3	2.1
		MTH-6432-APE0	460	3	1.0
		MTH-6532-APE0	575	3	0.8
	3/4 HP	MTH-6113-APE0	115	1	11.2
		MTH-6213-APE0	230	1	5.6
		MTH-6233-APE0	208	3	3.2
		MTH-6433-APE0	460	3	1.5
		MTH-6533-APE0	575	3	1.2
	1 HP	MTH-6114-APE0	115	1	13.6
		MTH-6214-APE0	230	1	6.8
		MTH-6234-APE0	208	3	4.4
		MTH-6434-APE0	460	3	2.1
		MTH-6534-APE0	575	3	1.6

• Track Hardware

For more details about the track hardware, please consult inside sales.

	Code	Door height
#41	T107	Up to 7'
	T108	Up to 8'
	T110	Up to 10'
	T112	Up to 12'
	T114	Up to 14'
	T116	Up to 16'
	T118	Up to 18'
	T120	Up to 20'

• Apartment version with instant reverse motor

	Code	Volt	Ph	Amp.	
APE1	1/2 HP	MTH-6112-APE1	115	1	8.0
		MTH-6212-APE1	230	1	4.0

For 50Hz operators, please consult inside sales.

Options

• Mechanical Modifications

Modification No	Options
MOD055	Double 4L V belt
MOD072	Pillow block bearings on output shaft
MOD073	Very heavy duty front idler

To help extend the life of the drive system, pillow block bearings and a very heavy duty front idler (with ball bearings) can be installed.

• Electrical Modifications

Modification No	Options
MOD004	Fail safe safety edge circuit
MOD008	Double limit switch (per pole)
MOD016*	Wiring for traffic lights

* **Note:** Only available on 115V 1Ph operators.