

AUXILIARY AUX THX	1	6	HEX HEAD BOLT 3/8 x 1 1/4	BOLT026	.
	2	1	HEX BOLT.375-16unc2.25	BOLT031	.
	3	1	TAKE UP BOLT 3/8 X 2 1/2	BOLT035	.
	4	1	EYEBOLT13/8 X 3	BOLT061	.
	11	10	NUT 3/8	NUT010	.
	15	8	LOCK WASHER 3/8	WASHER030	.
	17	2	HEX NUT 10-32 NYLON	NUT019	.
	18	2	10/32X1 BLACK BOLT W/NYLON NUT	SCREW025	.
	21	1	STOP NUT 3/8	NUT022	.
	5	1	TROLLEY FRONT END U-BRACKET	BRACKET043	A
	6	1	DIE CAST ALUMINIUM CARRIAGE	CARRIAGE004	.
	7	2	SOLID COUPLING 1"	COUPLING005	.
	8	1	DOOR LIFTING ARM ASS. TROLLEY	DOORARM001	.
	9	2	FRONTIDLER#41 H.D. OR #410 H.D	FRONTIDLER006-009	-/A
	10	1	FRONTIDLER ASSEMBLY #41 OR #410	FRONTIDLER010-007	-/C
	12	1	BEARING PLATE ID 1" OFF. 5"	PLATE083	.
	13		TROLLEY TRACK SPACER	SHAFT017	C
	16	4	SQUARE SHAFT KEYS 1/4 X 1-1/2	KW019	A
	14	1	SHAFT 1", 12 FT WITH KW 1/4	SHAFT075	E
	19	4	TRACK	TRACKxxx	.
20	2	TROLLEY CHAIN #41 OR #410 C/W LINK	THxxx	.	

#	QTY	DESCRIPTION	# MANARAS	REV
1	6	HEX HEAD BOLT 3/8 x 1 1/4	BOLT026	.
2	1	HEX BOLT.375-16unc2.25	BOLT031	.
3	1	TAKE UP BOLT 3/8 X 2 1/2	BOLT035	.
4	1	EYEBOLT13/8 X 3	BOLT061	.
11	10	NUT 3/8	NUT010	.
15	8	LOCK WASHER 3/8	WASHER030	.
17	2	HEX NUT 10-32 NYLON	NUT019	.
18	2	10/32X1 BLACK BOLT W/NYLON NUT	SCREW025	.
21	1	STOP NUT 3/8	NUT022	.
6	1	DIE CAST ALUMINIUM CARRIAGE	CARRIAGE004	.
8	1	DOOR LIFTING ARM ASS. TROLLEY	DOORARM001	.

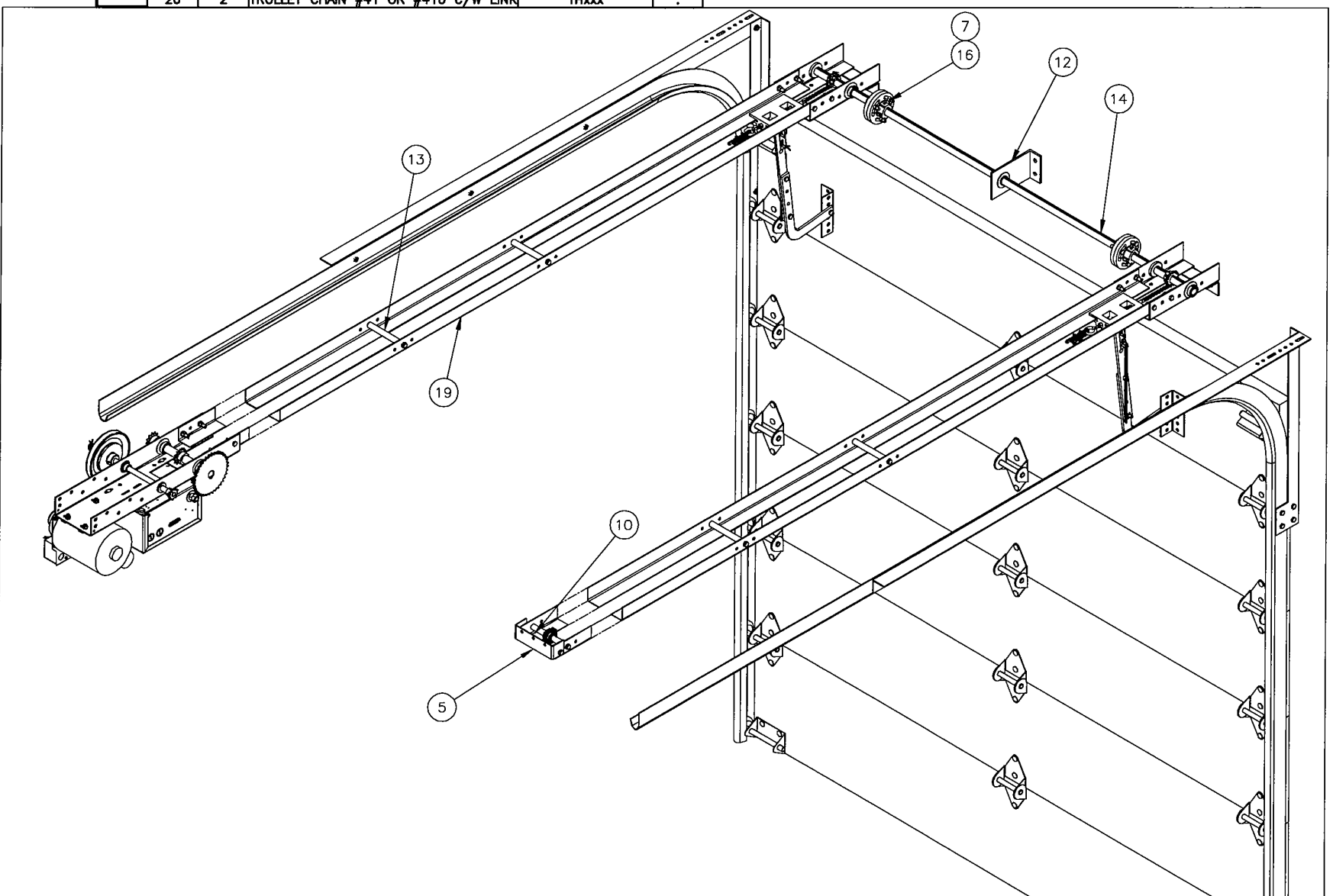
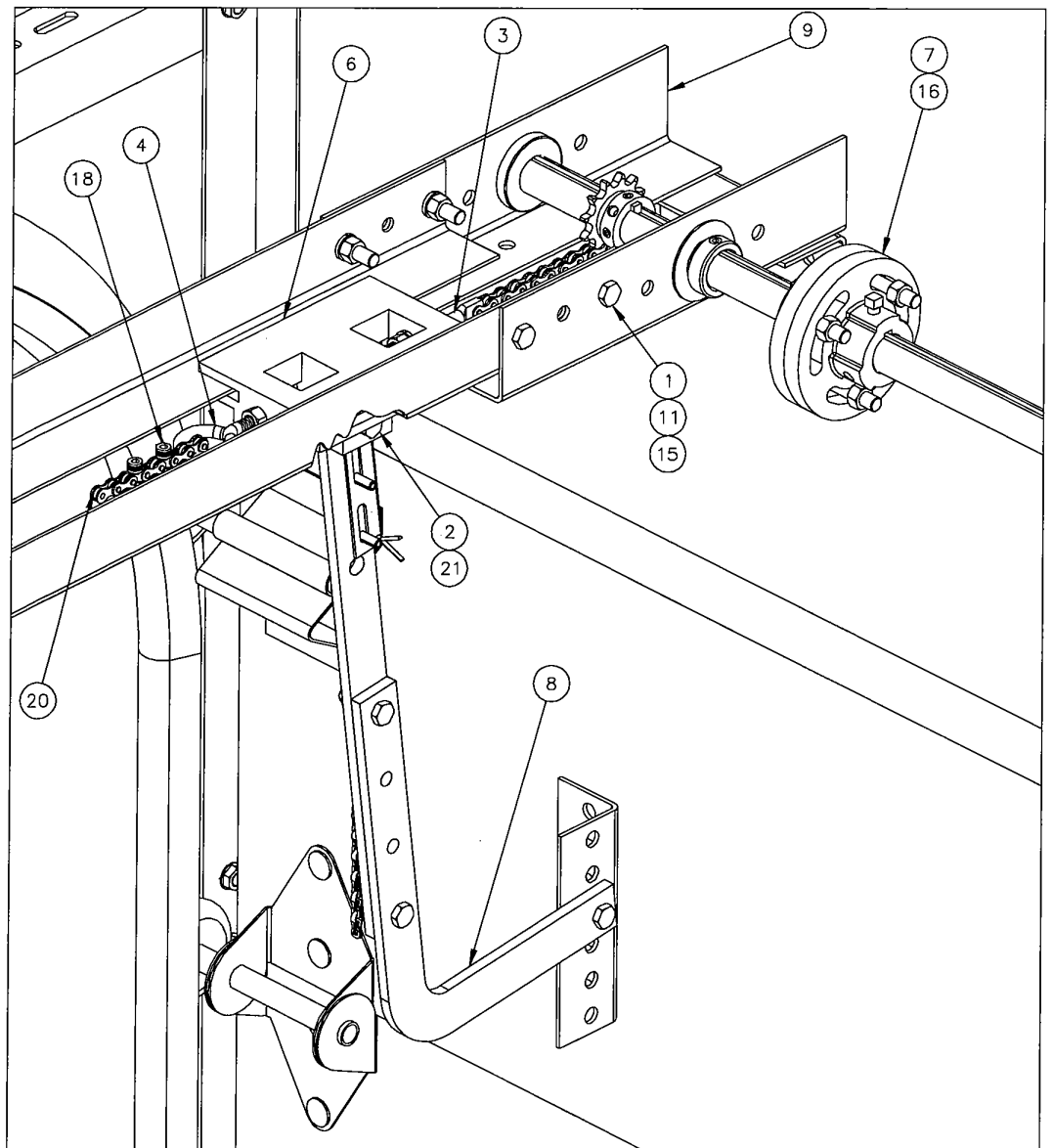

**NOTE:** MOD062 - DUAL TROLLEY DRIVE #48 CHAIN  
 MOD063 - DUAL TROLLEY DRIVE #41 CHAIN

THE INFORMATION CONTAINED HEREIN IS PROPRIETARY TO MANARAS AND SHALL NOT BE REPRODUCED OR DISCLOSED OR USED FOR ANY DESIGN OR MANUFACTURE EXCEPT WHEN USER POSSESSES DIRECT WRITTEN AUTHORIZATION FROM MANARAS.

**TITLE: DUAL TROLLEY DRIVE INSTALL. (MOD062)**

DESIGN BY:	NICOLAS VIAU	DATE:	04.01.05	QTY FILE:	DUAL TROLLEY DRIVE	REV:	2008.03.12
------------	--------------	-------	----------	-----------	--------------------	------	------------

MANARAS-OPERA  
 136 ONEIDA DRIVE  
 POINTE-CLAIRE, QC, H9R 1A8  
 TEL: 1-800-361-2260  
 FAX: 1-888-626-0606